

Reinventing
flow.
Since 1964

P

Normal-Priming Turbine Pumps
Made of PVDF or PP with Magnetic Coupling

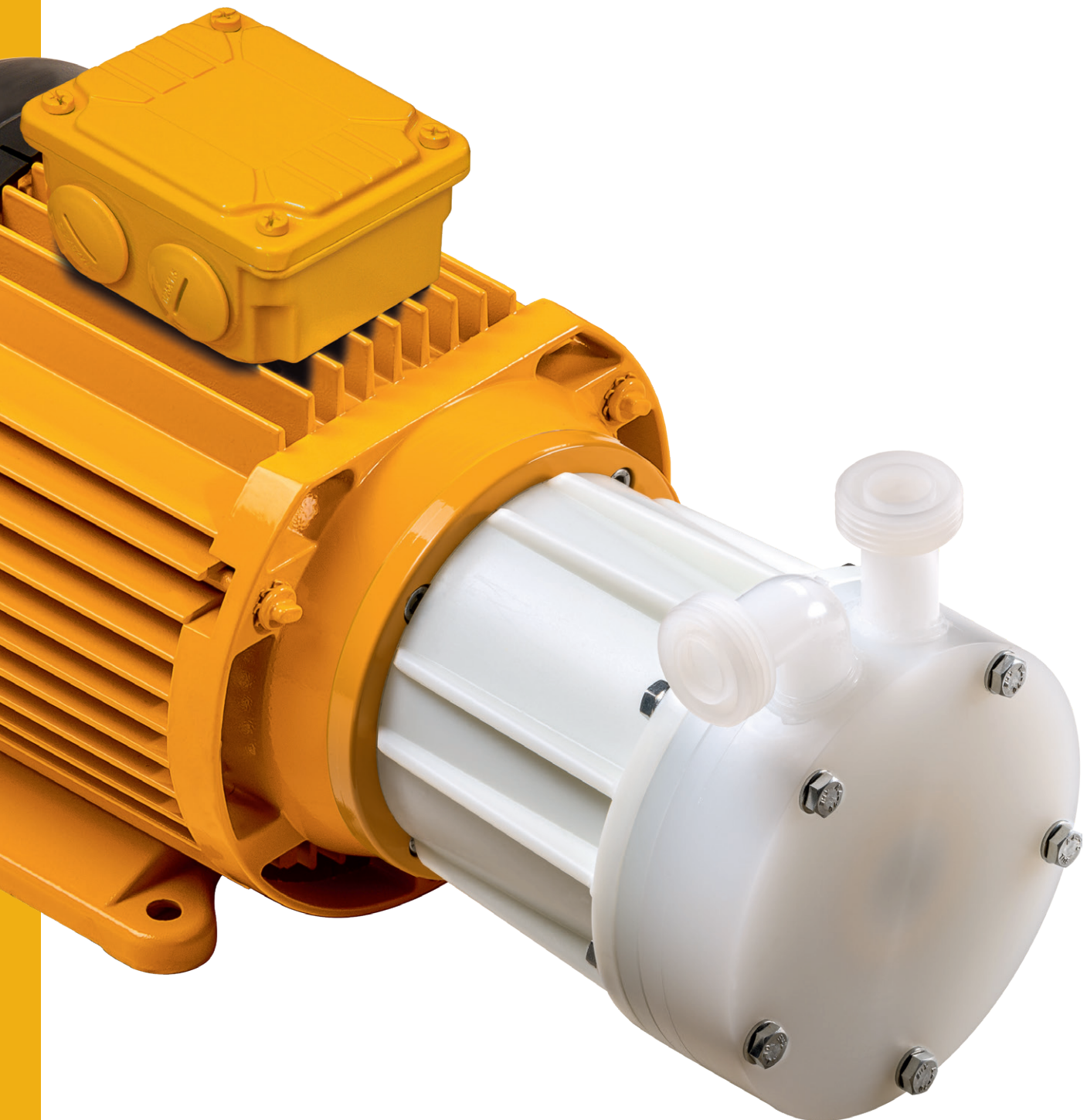



Normal-Priming Turbine Pumps

Made of PVDF or PP with Magnetic Coupling

Housing and impeller materials

PVDF, PP

Elastomers

EPDM, FKM (e.g. Viton®), FEP, FFKM (e.g. Kalrez®)

Bearing material pairings

SiC / SiC, PTFE-GF / Al₂O₃ ceramic

The P series is designed based on the peripheral turbine principle. Its specialized impeller and casing geometry enable the generation of high discharge pressures. Torque is transmitted contact-free and abrasion-free via a magnetic coupling through the hermetically sealed containment shell to the impeller, eliminating the need for a mechanical seal.

Pump Curve/Power Consumption p 140

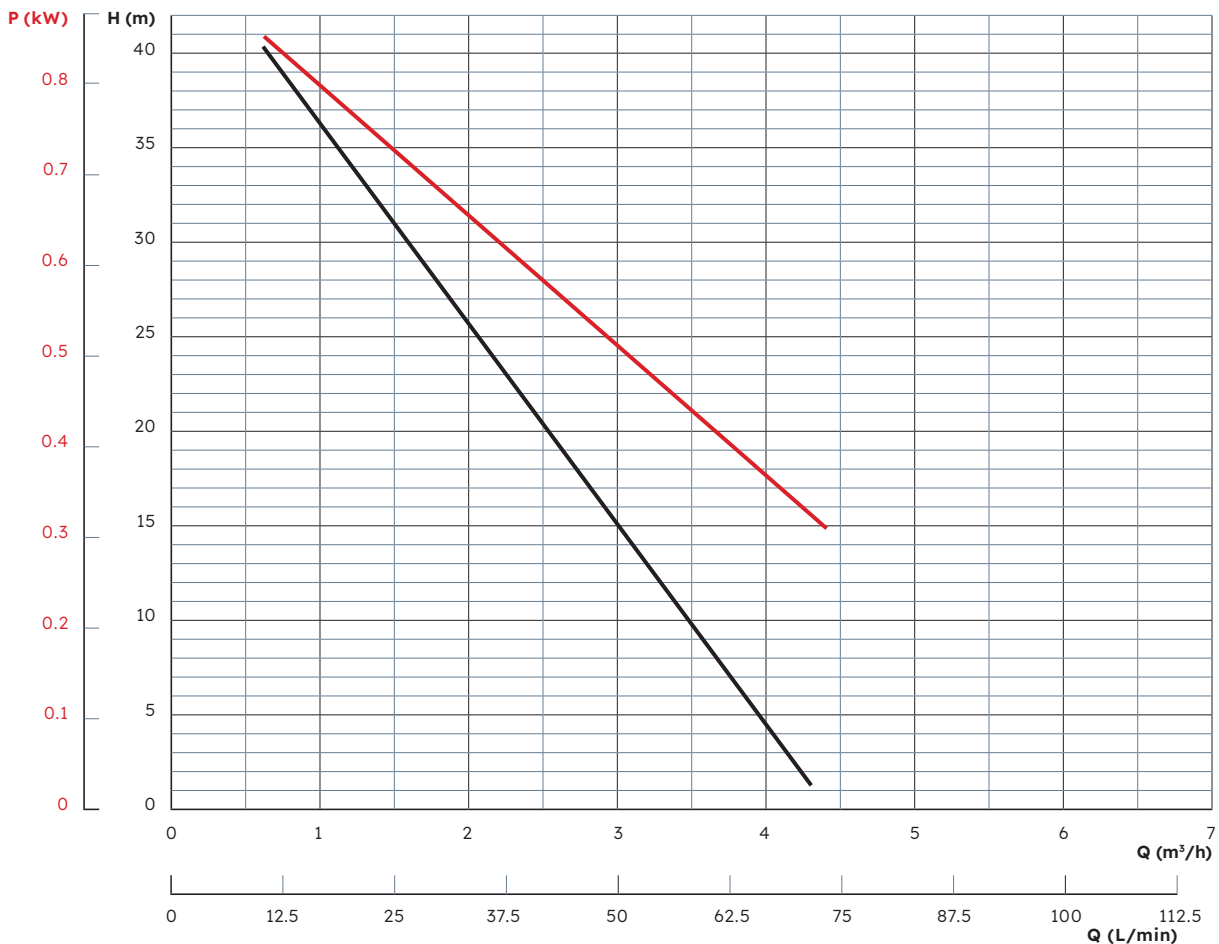

Normal-Priming Turbine Pumps
Made of PVDF or PP with Magnetic Coupling

Advantages

- + Very precise pump control due to linear pump curve
- + Hermetically sealed and absolutely leak-free (no mechanical seal)
- + Particularly suited for toxic, environmentally harmful and corrosive media
- + Very suitable for pumping low-boiling liquids

The maximum allowed temperature is 60 °C. All sizes are also available in ATEX-certified versions under the name P-EX for ATEX Zone 2.

Built for Pressure

Designed to generate high discharge pressures at low flow rates.

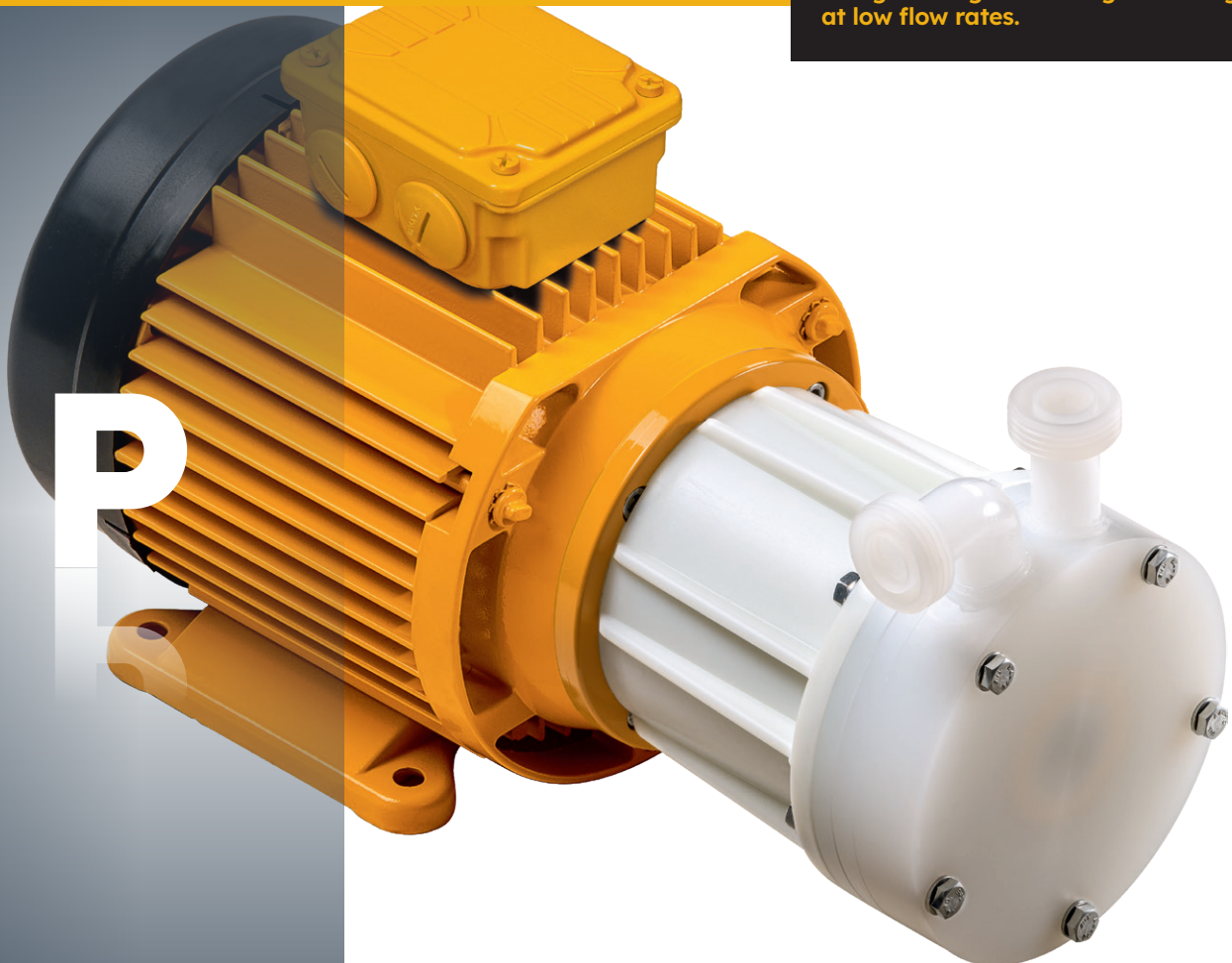

Description

Characteristics

Chemical-resistant, single-stage, magnetic drive turbine pump

Features

- Hermetically sealed and absolutely leak-free (no mechanical seal)
- Powerful magnetic drive with neodymium magnets
- Practically maintenance-free in normal operation due to extra-large slide bearings design without impeller shaft
- All wet parts made of high-quality, corrosion-resistant plastics (PVDF or PP)
- Threaded connections (ISO 228-1) as standard
- Optionally available with flanges (from size 130)
- Universally applicable, low-noise and compact close-coupled design
- Approved for use in explosive atmospheres ATEX zone 2
- Corrosion-resistant paint finish
- All stainless steel screws in 1.4571 (316Ti)
- FDA-certified materials (PVDF versions)

Fields of application

Delivery of acids, bases, lye or other corrosive, harmful or toxic liquids in such applications, where even small leakages are not acceptable and a hermetically sealed pump is required.

Delivery of highly pure and sensitive liquids, where contamination must absolutely be avoided.

For example in the following applications:

- Plating and surface coating
- Semiconductor technology and solar cell production
- PCB and electronics manufacturing
- Wastewater and fresh water treatment
- Laboratory equipment and medical technology,
- Emission controls and gas scrubbers
- Battery production and energy storage
- High-purity applications, demineralized water, ultrapure water

Characteristics

Available materials

- Pump housing / wet end: PVDF, PP
- Elastomers: FKM, EPDM, FEP, FFKM
- Bearing material pairings: SiC / SiC, PTFE-GF / Al₂O₃ ceramic

Standard motors

(available from stock)

- Three-phase motors: Δ230/Y400 V, 3-ph @ 50 Hz; Y460 V, 3-ph @ 60 Hz; IP55, Class F, with PTC as standard
- All three-phase motors from 0.75 kW comply with energy efficiency class IE3
- Single-phase motors: up to 1.1 kW: 230 V, 1-ph, 50/60 Hz, IP55, Class F
- ATEX-certified motors (temperature rating T3)

Special motors

(on request)

- Special voltages and frequencies
- Three-phase motors with integrated frequency converter
- ATEX-certified motors with flameproof enclosure and temperature rating T4
- Four-pole motors with 1450 rpm @ 50 Hz / 1650 rpm @ 60 Hz
- UL- and CSA-certified motors
- Special types of protection, e.g., IP65
- Special insulation classes, e.g., tropical insulation
- Multi-voltage, e.g., Δ220-290/Y380-500 V @ 50 Hz; Δ220-332/Y380-575 V @ 60 Hz
- Direct-current motors (DC or BLDC)

Operating conditions

- Max. flow rate: up to 4.5 m³/h
- Max. delivery head: up to 45 m
- Liquid temperature: 0 to 60°C (PVDF, PP)
- Ambient temperature: -10 to 40°C, higher temperatures on request
- Pumps can be adapted to high-density liquids (up to 1.3)

Dimensions

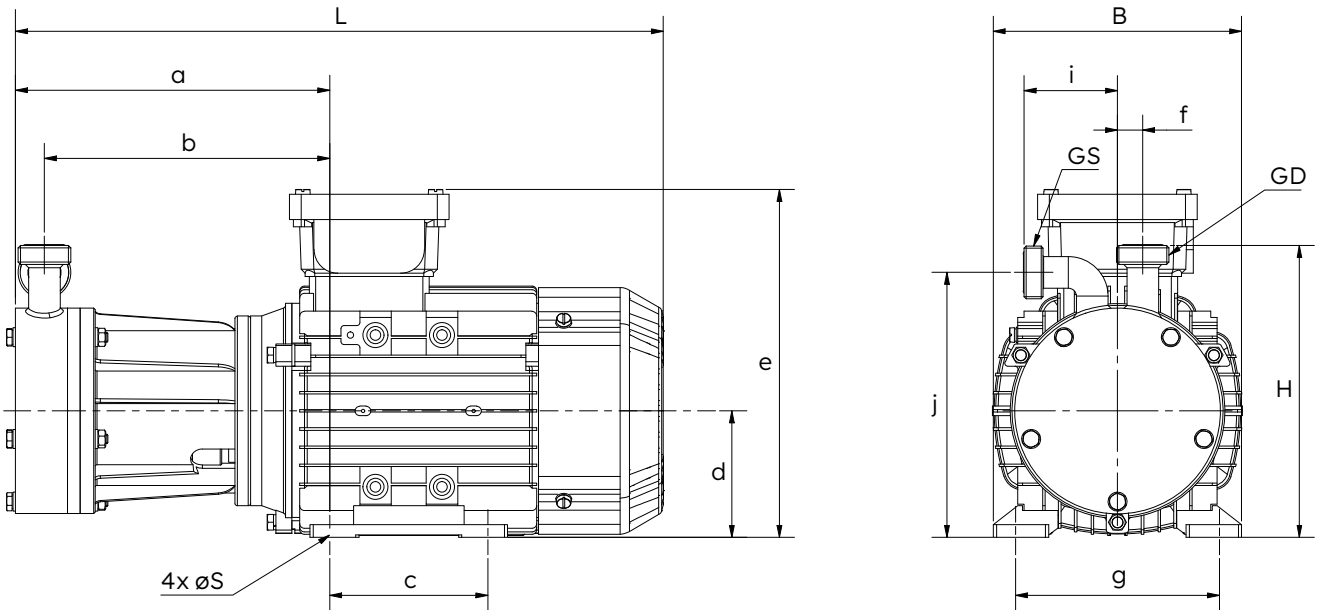

Typ	GS		GD		L (mm)	B (mm)	H (mm)	S (mm)	a (mm)	b (mm)	c (mm)	d (mm)	e (mm)	f (mm)	g (mm)
	Thread	DN	Thread	DN											
80	G½"	10	G½"	10	285	112	124	6	145	107	71	56	157	32	90
101	G¾"	15	G¾"	15	289	112	126	6	149	109	71	56	157	35	90
115	G¾"	15	G¾"	15	337	100	141	7	167	122	80	63	186	35	100
130	G1"	20	G1"	20	351	138	157	7	175	129	90	71	202	42	112
150	G1¼"	25	G1"	20	415	157	176	10	204	153	100	80	220	47	125
170	G1½"	32	G1¼"	25	473	173	200	10	234	175	125	90	191	55	140
191	G1½"	32	G1¼"	25	495	196	220	12	242	183	140	100	259	60	160
211	G2"	40	G1½"	32	517	227	242	12	253	189	140	112	304	70	190

All dimensions are provided for reference purposes only and are subject to change without notice. Dimensional variations may occur depending on motor type, manufacturer, or configuration. A certified dimensional drawing will be supplied with the official quotation or order confirmation.

Fittings

A comprehensive range of accessories is available for all Schmitt pumps, facilitating seamless integration into your system:

- + Flange adapters
- + Hose connectors
- + Weld-on fittings for stainless steel piping
- + Reducers and expanders
- + NPT-threaded adaptors
- + Inlet strainers for vertical pumps
- + Extension pipes for vertical pumps

Spare Parts

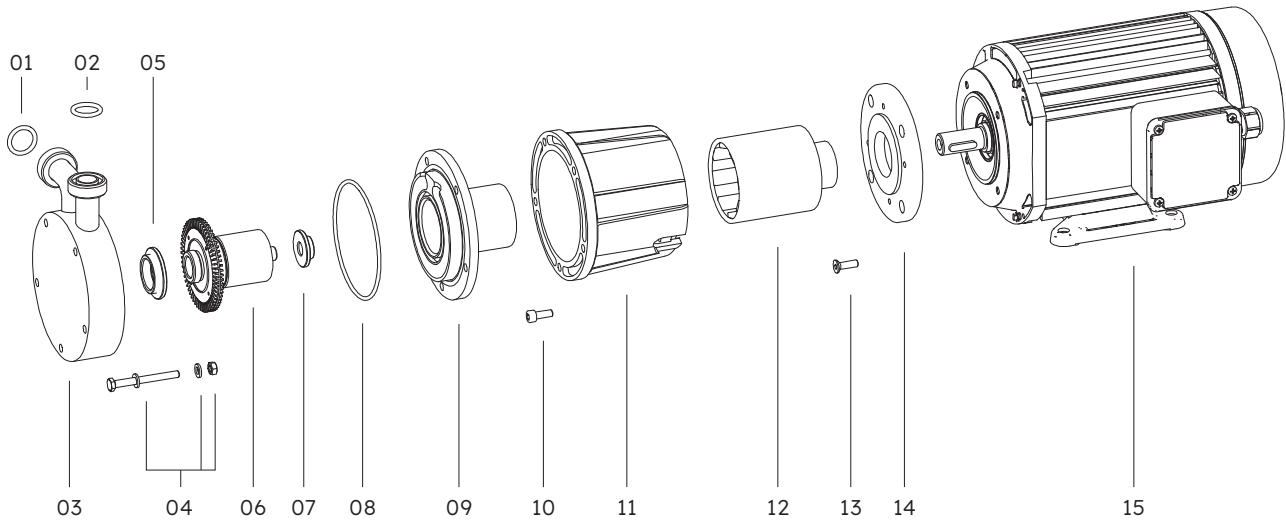

Position	Description	Available materials
1	O-ring (inlet port)	FKM, EPDM, FEP, FFKM
2	O-ring (outlet port)	FKM, EPDM, FEP, FFKM
3	Pump housing incl. slide bearing ring	Housing: PVDF, PP Ring: Al ₂ O ₃ , SiC
4	Hexagon bolt, washer, nut	V4A (1.4571)
5	Front bearing	PTFE, SiC
6	Impeller	PVDF, PP
7	Back bearing	PTFE, SiC
8	Housing seal	FKM, EPDM, FEP, FFKM
9	Backplate incl. slide bearing ring	Backplate: PVDF, PP Ring: Ceramics Al ₂ O ₃ , SiC
10	Cylinder head screw	V4A (1.4571)
11	Flange	PP
12	Drive magnet	
13	Cylinder head screw	V4A (1.4571)
14	Adapter plate	Aluminium
15	Motor	

SCHMITT

Reinventing flow. Since 1964

NHM

Normalausgange Kreiselpumpen
aus PVDF oder PP mit Magnetrkupplung



SCHMITT

Reinventing flow. Since 1964

MPN

Normalausgange Kreiselpumpen
aus PVDF oder PP mit Magnetrkupplung



SCHMITT

Reinventing flow. Since 1964

U

Normalausgange Kreiselpumpen
aus PVDF mit einfach-wirkender Gleitringdichtung



SCHMITT

T

Dichtunglose Einbaupumpen
aus PP oder PVDF, trockenlaufender

Reinventing flow. Since 1964



SCHMITT

UP | UP-DO

Normalausgange Kreiselpumpen
aus Edelstahl mit einfach oder doppelt-wirkender Gleitringdichtung

Reinventing flow. Since 1964



SCHMITT

Reinventing flow. Since 1964

SMP

Selbstansaugende Kreiselpumpen
aus PP mit Magnetrkupplung



SCHMITT

Reinventing flow. Since 1964

P

Normalausgange Peripherenrödpumpen
aus PVDF oder PP mit Magnetrkupplung



SCHMITT

NEOCHEM BASE

Chemie-Normpumpen
ETFE ausgekleidet, mit Magnetrkupplung

Reinventing flow. Since 1964



SCHMITT

NEOCHEM CORE

Heavy Duty-Chemie-Normpumpen
FFA ausgekleidet, mit Magnetrkupplung

Reinventing flow. Since 1964



Änderungen, die dem technischen Fortschritt dienen, behalten wir uns vor. Maße und Leistungsangaben unverbindlich. Stand 02/2026

SCHMITT-Kreiselpumpen GmbH & Co. KG
Einsteinstraße 33
76275 Ettlingen, Deutschland
T +49 7243 5453-0
F +49 7243 5453-22
sales@schmitt-pumpen.de
schmitt-pumpen.de

